

turbo 3-36

The FMB turbo 3-36 is a magazine for bar diameters of 3-38 mm.

It works on the principle of two-stage feed that characterises the turbo series. The swivelling pusher means that a very compact, space-saving construction can be achieved.

Area of application:

Long-turning or short-turning lathes with up to 38 mm nominal throughput gap, which process small and medium-sized diameter ranges.

Features

- Short design based on a two-stage feed principle (swivelling pusher)
- Fast, simple changing of the inserts for efficient adaptation of the guide channel to different material diameters
- Maximum vibration damping from the use of plastic inserts in conjunction with a torsion-resistant aluminium support system.

Available installation situations

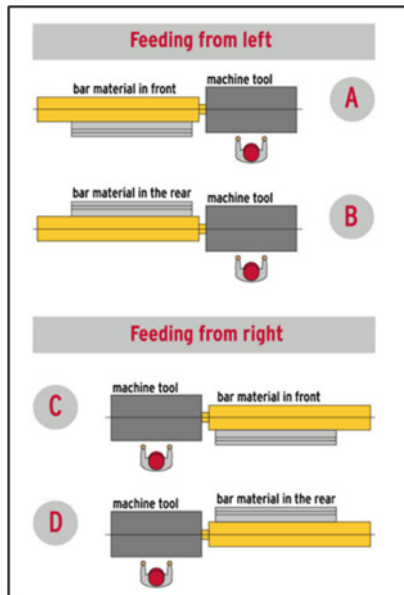

Ergonomic and simple operation

Mobile control panel



Easy handling of the FMB loading magazine is supported by a detachable user-friendly control panel. It can be combined with a high-performance programmable logic control (PLC) system to enable FMB to produce very flexible customer-specific special functions and processes.

Efficient, practical handling

Installation position

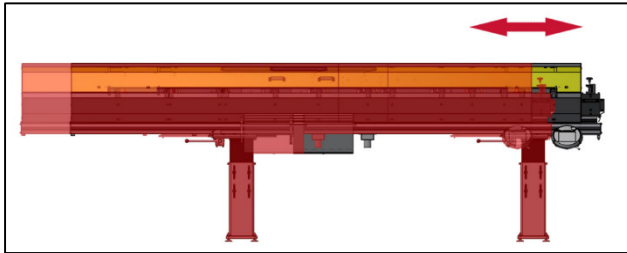

The optional shifting device makes it possible to move the loading magazine up to 400 mm away from the lathe. This practical feature increases accessibility to the lathe for service technicians, e.g. when replacing spindle liners, or, when switching variable lathes from short-turning to long-turning mode, ensures the shortest distance between loading magazine and spindle stock at all times.

Guide channel inserts

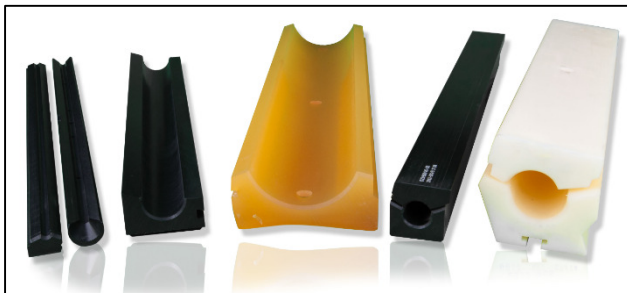

The guide channel inserts are quick easy to replace so that the channel diameter can be adapted to the optimum diameter range of the material bars to be processed.

Stable design

Machine support

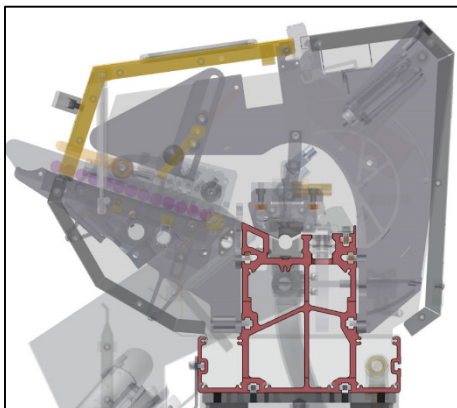

The torsion-resistant machine support of extruded aluminium forms the solid basis for the loading magazine. It also holds the diameter-related inserts for the guide channel.

Material bar grippers

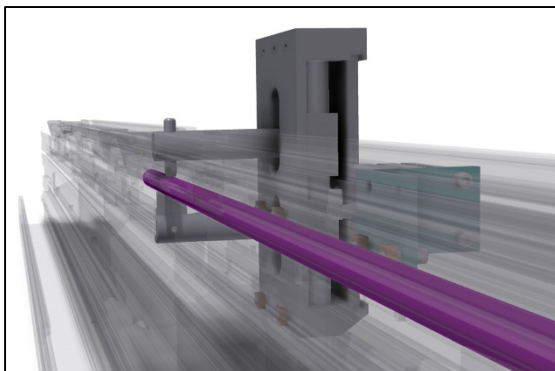

The stable gripper design guarantees secure drawing in of the material bar and removal of the remnant piece.

Optimum material bar guidance

Synchronizing device

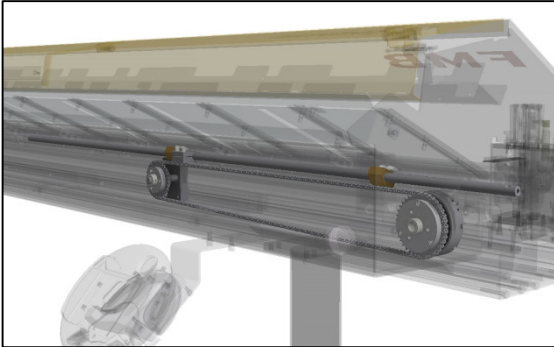

When using a moving spindle stock (e.g. in long-turning mode), the synchronizing device uses a coupling system to couple the bar feed device of the loading magazine mechanically to the spindle stock, thus ensuring synchronisation with the movement of the pusher. As an option, the position during this movement can also be monitored by a sensor to prevent any possible collisions, e.g. when switching from short-turning to long-turning mode.

Steady

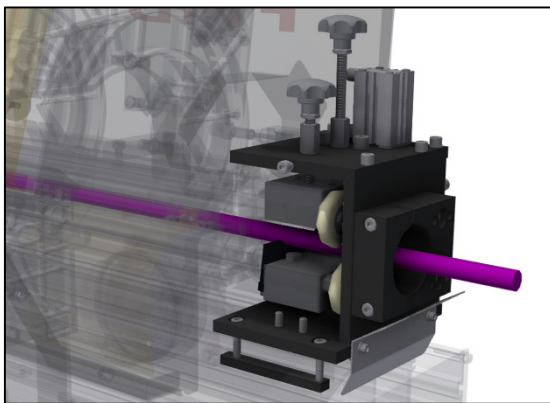

The steady at the end of the guide channel takes the form of a flexible roller steady for the processing of round material bars. When processing round, square and hexagonal section materials the guide rollers can be replaced by appropriate material guides (guide jaws). This enables the steady to be set to the dimensions of the material bar, thus guaranteeing optimum guidance even of small-diameter bars in a larger guide channel.

Telescopic tube

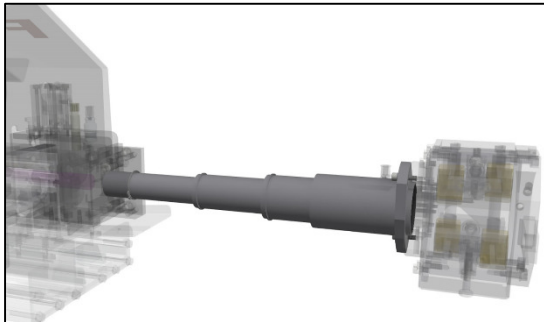

Telescopic tubes are used to bridge the gap when fitting a bar loading magazine to a lathe with a moveable spindle stock. FMB offers an optional package to suit each type of lathe, to ensure secure protection of the rotating bar and the best possible guidance.

Spindle stock steady

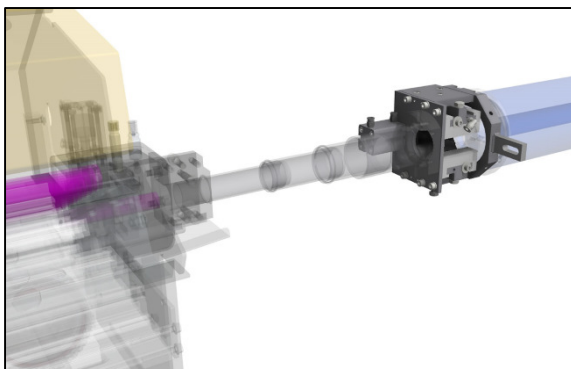

In addition to the use of a telescopic tube, FMB offers a moving steady for lathes with large travel distances along the Z axis and long spindles. This is linked to the spindle stock, thus offering an additional support point for the material bar in order to reduce the free length between the steady and the collet in the lathe. It reduces vibrations in the material bar and has a positive effect on the production quality of the parts.

Spindle liners



On request FMB can also supply spindle liners to match a substantial number of lathe types; these enable the spindle opening to be optimally adapted to match the guide channel diameter.

Technical data

Bar length ¹⁾	2200 mm	3200 mm	4200 mm	6200 mm
Bar diameter	3 - 38 mm	3 - 38 mm	3 - 38 mm	3 - 38 mm
Loading capacity	200 mm	200 mm	200 mm	200 mm
Remnant piece length (max)	450 mm	450 mm	450 mm	450 mm
Loading time (approx.)	-	26 s	-	-
Feed speed	0-700 mm/s	0-700 mm/s	0-700 mm/s	0-700 mm/s
Return speed	0-1000 mm/s	0-1000 mm/s	0-1000 mm/s	0-1000 mm/s
Power requirement	1.5 kW	1.5 kW	1.5 kW	1.5 kW
Compressed air connection	0.6 / 6 bar MPa	0.6 / 6 bar MPa	0.6 / 6 bar MPa	0.6 / 6 bar MPa
Weight without oil	550 kg	750 kg	1000 kg	1500 kg

1) Special lengths on request